













ASSEMBLY INSTRUCTION FOR DUC001

****Thank you for purchasing quality product. Be sure to check all packing material carefully for small parts that may have come loose inside the carton during shipment.**

Notes: Place all wooden parts on a clean and smooth surface such as a rug or carpet to avoid scratching the product. Kindly follow the assembly instructions by step.

Do not tighten all screws and bolts until the chair is fully assembly.

WOODEN PARTS			
NO	PART NAME	SYMBLE	QTY
1	Chair back frame		1Pc
2	Front legs		2Pcs
3	Seat panel		1Pc
4	Stretchers		2pcs

HARDWARE PARTS			
NO	PART NAME	SYMBLE	QTY
A	Bolt Ø8x70mm		4Pcs
B	Hexagonal wrench		1Pc
C	Bolt Ø8x40mm		2Pcs
D	Screw Ø4x40mm		4Pcs
E	Nut Ø8x10mm		4Pcs
F	Key wrench		1Pc
G	Flat washer Ø8x2mm		10Pcs
H	Spring washer Ø8x3mm		10Pcs

STEP 1

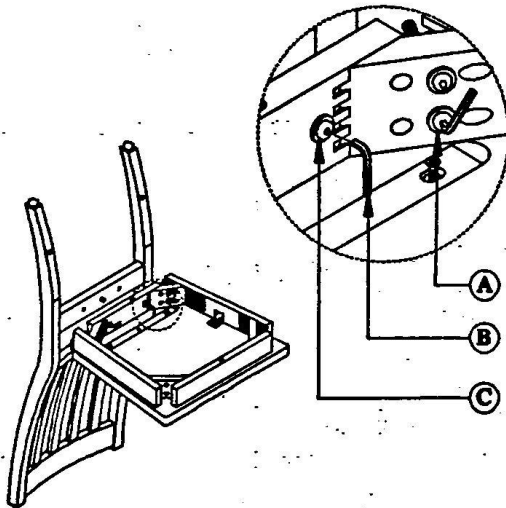

STEP 2

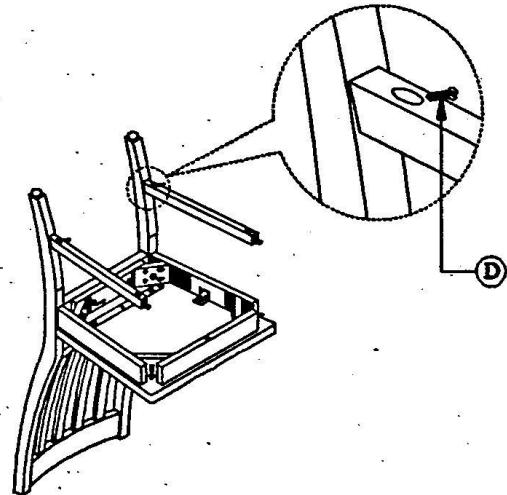

STEP 3

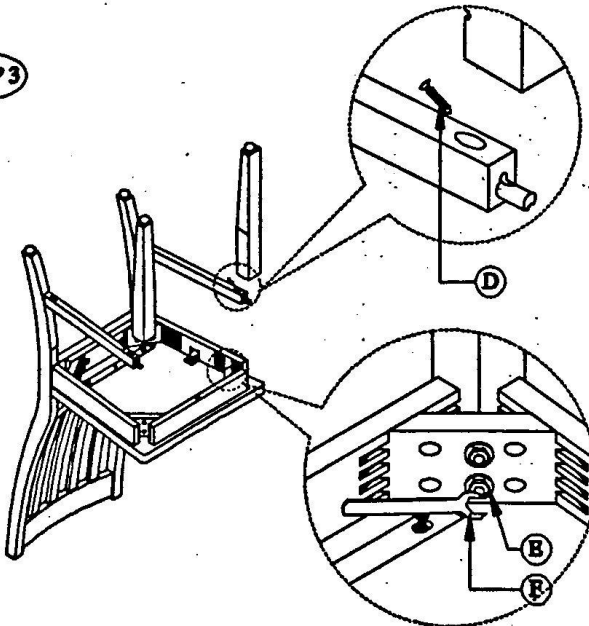

VIEW

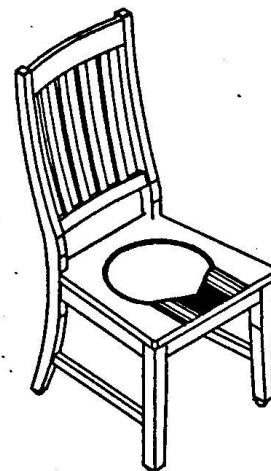

View Perspective